

WHEEL BEARING PACKER

FOR BEARINGS WITH MAX. 3-1/4" O.D. X 5/8" TO 1-1/2" I.D.
FOR USE WITH 25 OR 35 LB. CONTAINER.

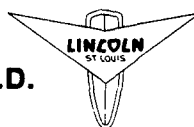

Model 102697

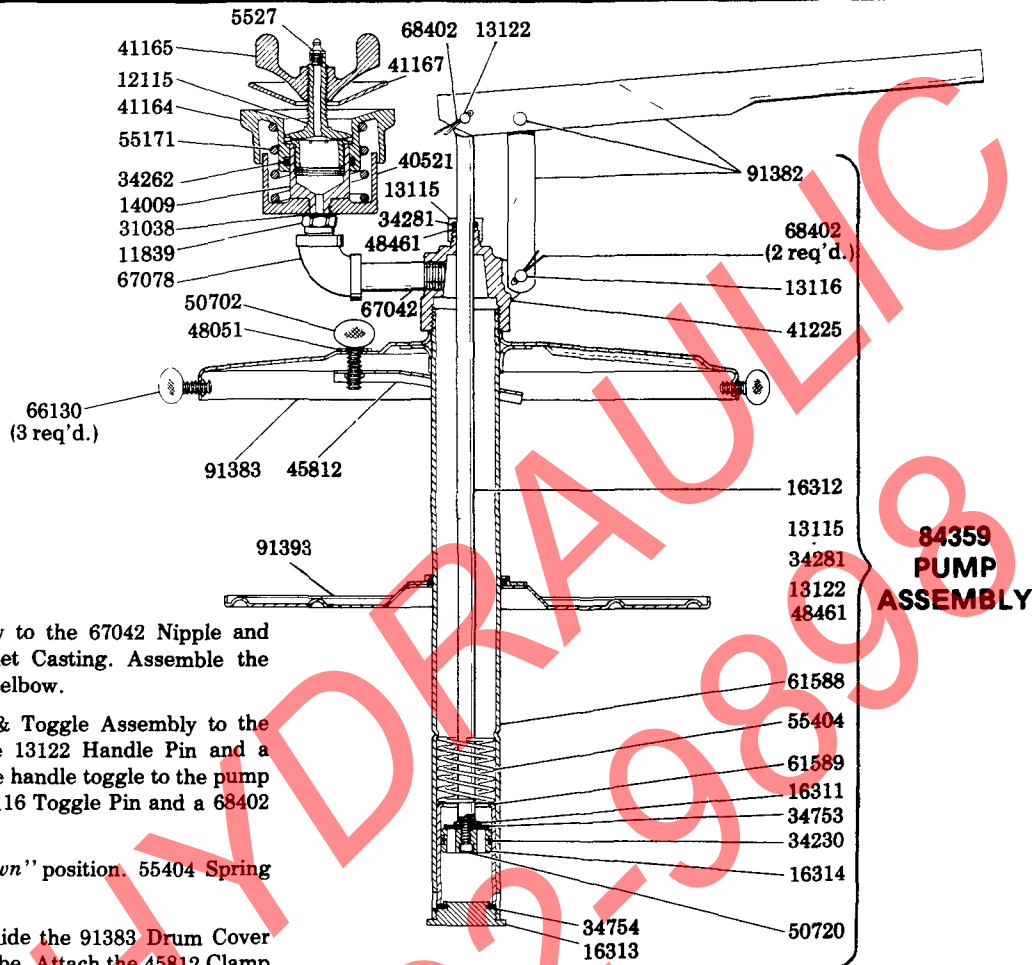

PUMP ASSEMBLY

- 1) Assemble the 67078 Elbow to the 67042 Nipple and screw into the 41225 Outlet Casting. Assemble the wheel bearing packer to the elbow.
- 2) Attach the 91382 Handle & Toggle Assembly to the 16312 Piston Rod with the 13122 Handle Pin and a 68402 Cotter Pin. Attach the handle toggle to the pump outlet casting using the 13116 Toggle Pin and a 68402 Cotter Pin.
- 3) Hold the handle in the "down" position. 55404 Spring must be compressed.
- 4) Remove the 16313 Plug. Slide the 91383 Drum Cover Assembly onto the pump tube. Attach the 45812 Clamp to the drum cover assembly using the 50702 Thumb Screw and 48051 Washer. Do not tighten thumb screw, the pump tube should slide freely through clamp & drum cover.
- 5) Slide the 91393 Follower Assembly onto the pump tube.
- 6) With handle remaining in the down position, insert the 16313 Plug into the pump tube and hand tighten.
- 7) Assemble the three 66130 Thumb Screws into the drum cover rim.
- 8) Remove lubricant container cover, push pump tube a short distance into lubricant at center of the container and guide the 91393 Follower Assembly into the container. Position the drum cover over the rim of the lubricant container and secure with the three thumb screws.
- 9) Push pump tube down through the drum cover until pump rests on lubricant container bottom. Secure the pump by tightening the 50702 Thumb Screw on top of the drum cover.

SERVICE PARTS

PART	DESCRIPTION	PART	DESCRIPTION	PART	DESCRIPTION	PART	DESCRIPTION
5527	Fitting	16314	Piston	41167	Adapter ring	61589	Slide valve
11839	Adapter	31038	Gasket	41225	Outlet casting	66130	Thumb screw
12115	Locating stud	34230	O-ring	45812	Clamp	67042	Nipple
13115	Gland nut	34262	O-ring	48051	Washer	67078	Elbow
13116	Toggle pin	34281	Gland packing	48461	Washer	68402	Cotter pin
13122	Handle pin	34753	Check	50702	Thumb screw	84359	Pump assembly
14009	Sleeve	34754	Gasket	50720	Screw	91382	Handle & toggle assembly
16311	Retainer	40521	Body casting	55171	Spring	91383	Drum cover assembly
16312	Piston rod	41164	Head casting	55404	Spring	91393	Follower assembly
16313	Plug	41165	Wing knob	61588	Pump tube		

LINCOLN ST. LOUIS
4010 GOODFELLOW BLVD · ST. LOUIS, MO 63120 · (314) 383 5900



A DIVISION OF
McNEIL
CORPORATION

SECTION - **F58**
PAGE - **3A**

APPLICATION FOR ROLLER BEARINGS

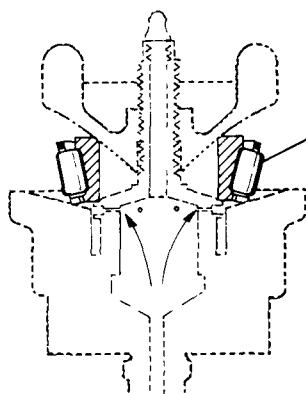

BEARING
(LARGE DIAMETER UP)

Position of bearings having inside diameters larger than 7/8" and up to 1-1/2" diameter.

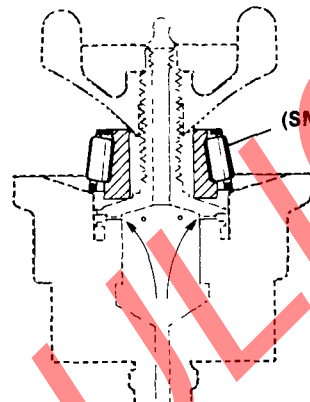

BEARING
(SMALL DIAMETER UP)

Position of bearings having inside diameters larger than 5/8" and up to 7/8" diameter.

NOTE

Turn the 41165 Wing Knob until the 41164 Head Casting is completely depressed and bearing is held tight.

Bearings can be flushed and packed by pumping handle of pump until clean grease appears on bearing.

Multi-purpose grease used for chassis lubrication is also used for wheel bearing packer.

APPLICATION FOR BALL BEARINGS

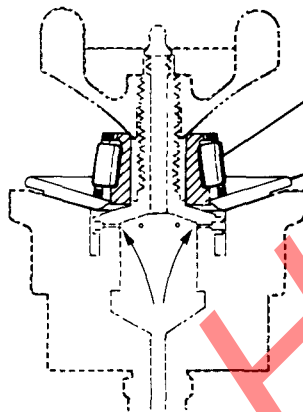

BEARING
(SMALL DIAMETER UP)
ADAPTER RING

Use 41167 Adapter Ring with 5/8" inside diameter bearing.

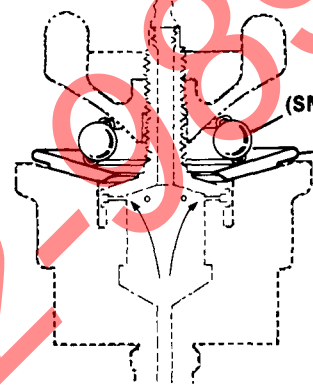

BEARING
(SMALL DIAMETER UP)
ADAPTER RING

Use 41167 Adapter Ring as shown with ball type bearing.

LUBRICANT SELECTION

Model 102697 Wheel Bearing Packer will prime easily and pump efficiently when using heavy grease at low temperatures; from a normal condition of NLGI #2 grease or less at 70° F to an extreme condition of NLGI #5 grease at 20° F. A slight pause should be allowed at the end of the downstroke of the handle to allow the grease to flow into the pump tube. In extreme conditions (#5 grease at 20° F) the handle should remain at the end of the downstroke for approximately 5 seconds.

PRIMING

It is necessary that the pump tube be filled completely with lubricant. Unscrew wheel bearing packer from 67078 Elbow. Operate handle until lubricant flows from elbow. If pump will not prime, pour approximately two ounces of clean lightweight oil into the outlet pipe and operate handle.

TROUBLESHOOTING

IF PUMP LOSES PRIME OR VOLUME DECREASES:

- 1) Check for empty lubricant container.
- 2) Dirt or foreign particles may be lodged in 61589 Slide Valve; clean thoroughly.
- 3) 34230 O-ring may be worn; remove and replace.
- 4) Dirt or foreign particles may be lodged in the 16314 Piston and 34753 Check; clean thoroughly.

NOTE: If lubricant leaks between the 16312 Piston Rod and 13115 Gland Nut, the 34281 Packing is worn. Remove and replace.

RETAIN THIS INFORMATION FOR FUTURE REFERENCE

When ordering replacement parts, list: Part Number, Description, Model Number, and Series Letter.
LINCOLN ST. LOUIS provides a Distributor Network that stocks equipment and replacement parts.
A list of Authorized Service Departments will be furnished upon request.